

GEM Hump Belt Blanchers

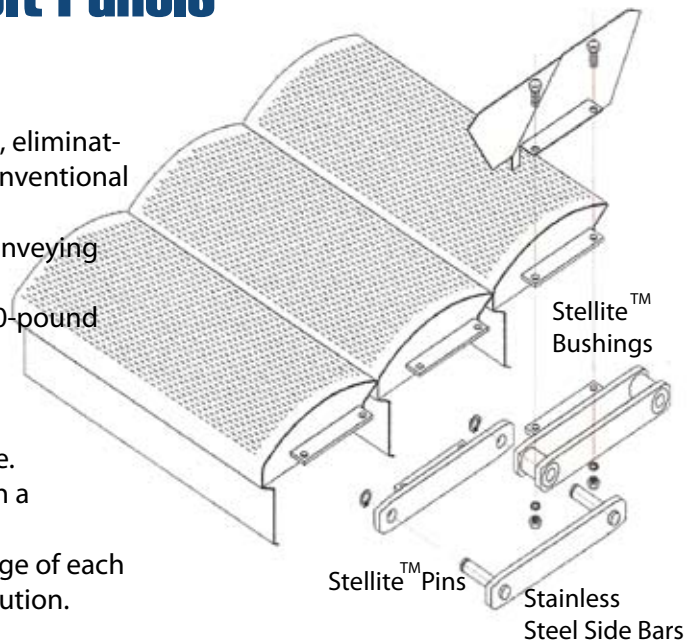

Stainless Steel Hump Belt Panels

- Unique platform conveyor belt design.
- Each panel is a segment of a circle.
- Panels form a circular drum at discharge, eliminating surge problems normally associated with conventional platform belts.
- The curved panels function as flights, conveying product up steeper slopes.
- Each perforated panel can support a 250-pound concentrated load.
- Easy-to-clean sanitary design.
- Dependable long life system.
- Tough corrosion resistant chain available.
- Delivers and discharges food products in a constant even flow.
- The narrow, unperforated area at the edge of each panel allows more uniform steam and air distribution.



In business since 1969

equipment OF OREGON inc.

P.O. Box 359/ 2150 Progress Way Woodburn, OR 97071 Telephone 503-982-9902
Fax: 503-981-6316 Email: gem@gemequipment.com Website: gemequipment.com

1-4-1-2011